



# Systeme GmbH

FCT Group

**Industrial applications using  
FCT high temperature furnaces for  
technical ceramics and powder metallurgy**

*R. Kirchner*

**FCT Systeme GmbH, Rauenstein – Germany**

## The FCT Group: Company locations in Germany

We are located in:  
Frankenblick  
Thuringia  
Germany



## The FCT Fine Ceramics Technologies Group

### FCT Companies, located in Thuringia / Germany:

- FCT Systeme GmbH : Advanced sintering technologies
- FCT Ingenieurkeramik GmbH : Non-oxide ceramics products
- FCT Hartbearbeitungs GmbH : Diamond grinding hard materials

### Some Figures (Company Group):

- established in 1982
- 2012 - 170 employees

## Advanced sintering technologies by FCT Systeme GmbH

- Machining → ceramic cutting tools
- Automotive industry → diesel particulate filters (DPF)  
→ C-SiC brake discs, SSiC seal, etc.
- PV industry → silicon melting / solidification
- Electronic industry → sputtering targets  
→ wafer handling components
- Refractories → kiln furniture, aluminium die casting components
- Powder metallurgy → PIM, MIM, cutting tools
- Air & spacecraft industry → protection systems
- Mechanical engineering → mechanical seal rings / valve components  
→ ball bearings, wear parts, etc.
- Ballistic → body armors / plates

## High-temperature equipment and technology:

- Gas pressure sintering furnaces
- Hot presses
- Ultra-high temperature induction furnaces
- High temperature resistant heated furnaces
- Solar silicon melting and solidification furnaces
- **Spark plasma sintering technology – “FAST”**
- Job orders and development support



## Lab gas pressure sintering furnace (FP W 12.5)



- 2400°C
- 10 MPa
- 1.25 - 25 dm<sup>3</sup>
- Ar / N<sub>2</sub> / He

## Sinter – HIP production furnace (FP W)

e.g. for  $\text{Si}_3\text{N}_4$  (YAG) and WC / Co cutting tools

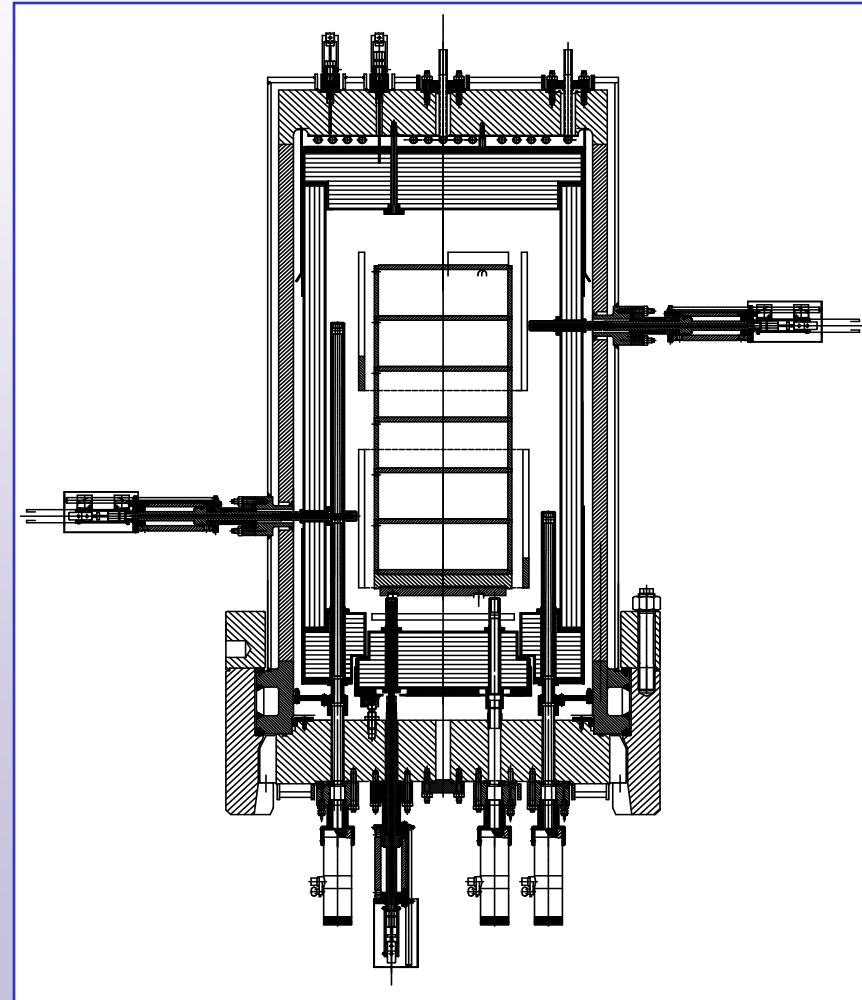

- 2200°C
- 10 MPa
- 90 dm<sup>3</sup>
- Ar / N<sub>2</sub>

## Roll milling application with GPSN ceramic parts

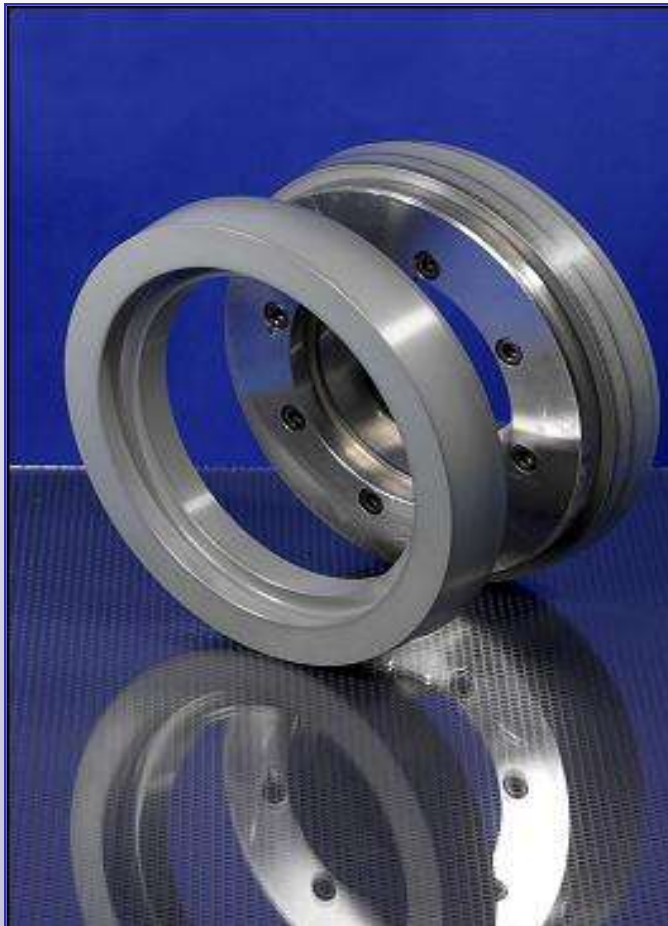



## Applications in aluminium melting metallurgy: $\text{Si}_3\text{N}_4$ riser tubes and heating tubes

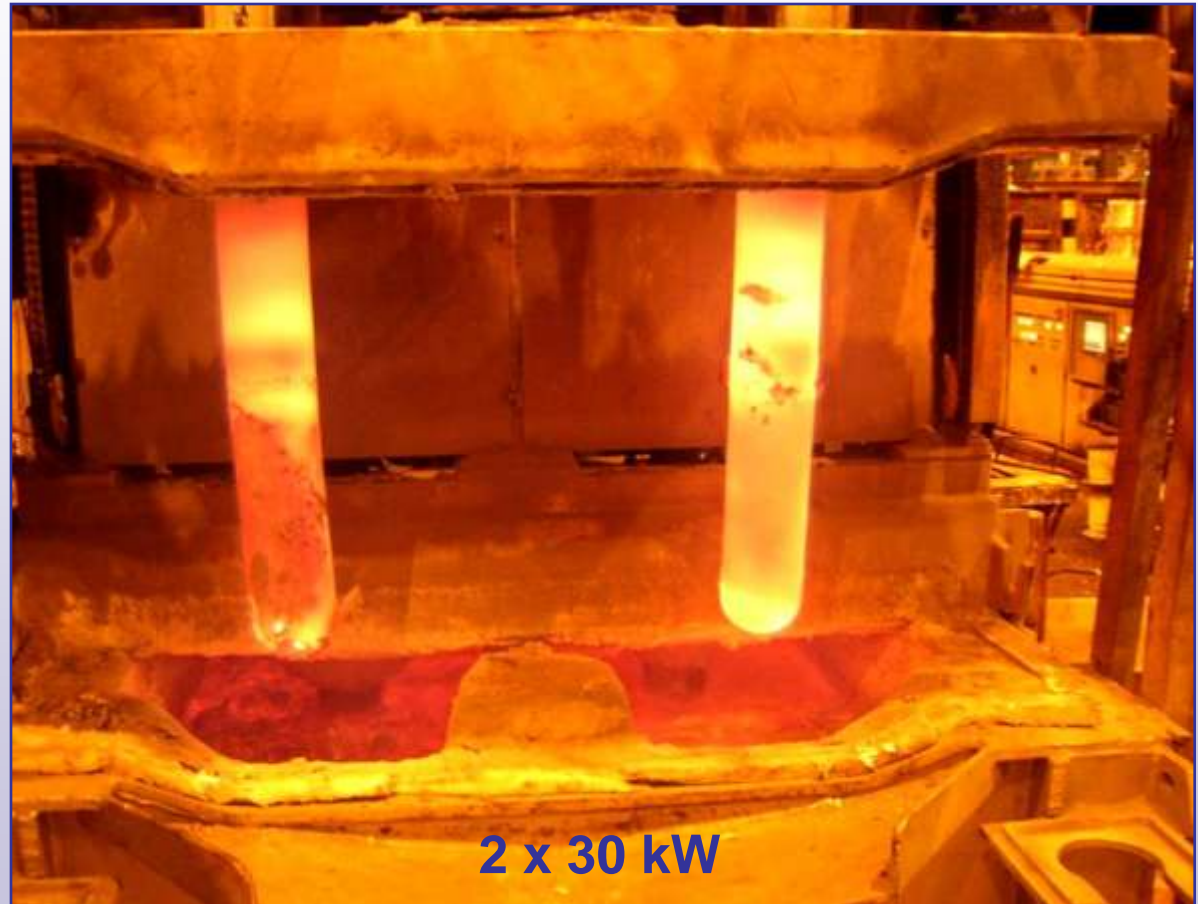

GPSN up to dia.150 mm and 1250 mm length

## Versatile high-temperature sintering furnace – 2500°C (FS I)



- 2500 °C
- 1.5 m<sup>3</sup>
- up to 5x10<sup>-2</sup> mbar
- Ar, N<sub>2</sub>, CO, He
- debinding
- fast cooling
  
- SSiC,
- LPSiC,
- RSiC,
- NSiC

## Applications

### Recrystallized RSiC diesel particulate filter



## Batch siliconizing furnaces for production line



- 1800 °C
- 1 m<sup>3</sup>
- Ar / N<sub>2</sub>
- 10<sup>-2</sup> mbar
  
- debinding – pyrolysis – siliconizing
- C/SiC - brake discs

## Applications Composite material C/SiC

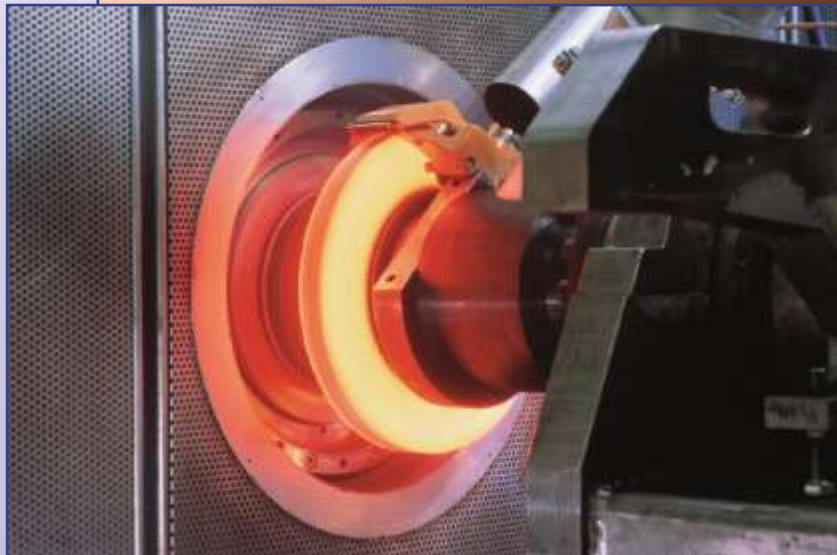

clutch and brake linings

## Advanced sintering furnace (FH W)



- useful volume  
2200 x 2400 x 1100 mm
- rated temperature 2200°C
- controlled atmosphere  
Ar, N<sub>2</sub>, He,  
up to 5 x10<sup>-2</sup> mbar
- SSiC
- heat treatment

## Applications mass production of seal rings made of SSiC



## Advanced sintering furnace (FH I)

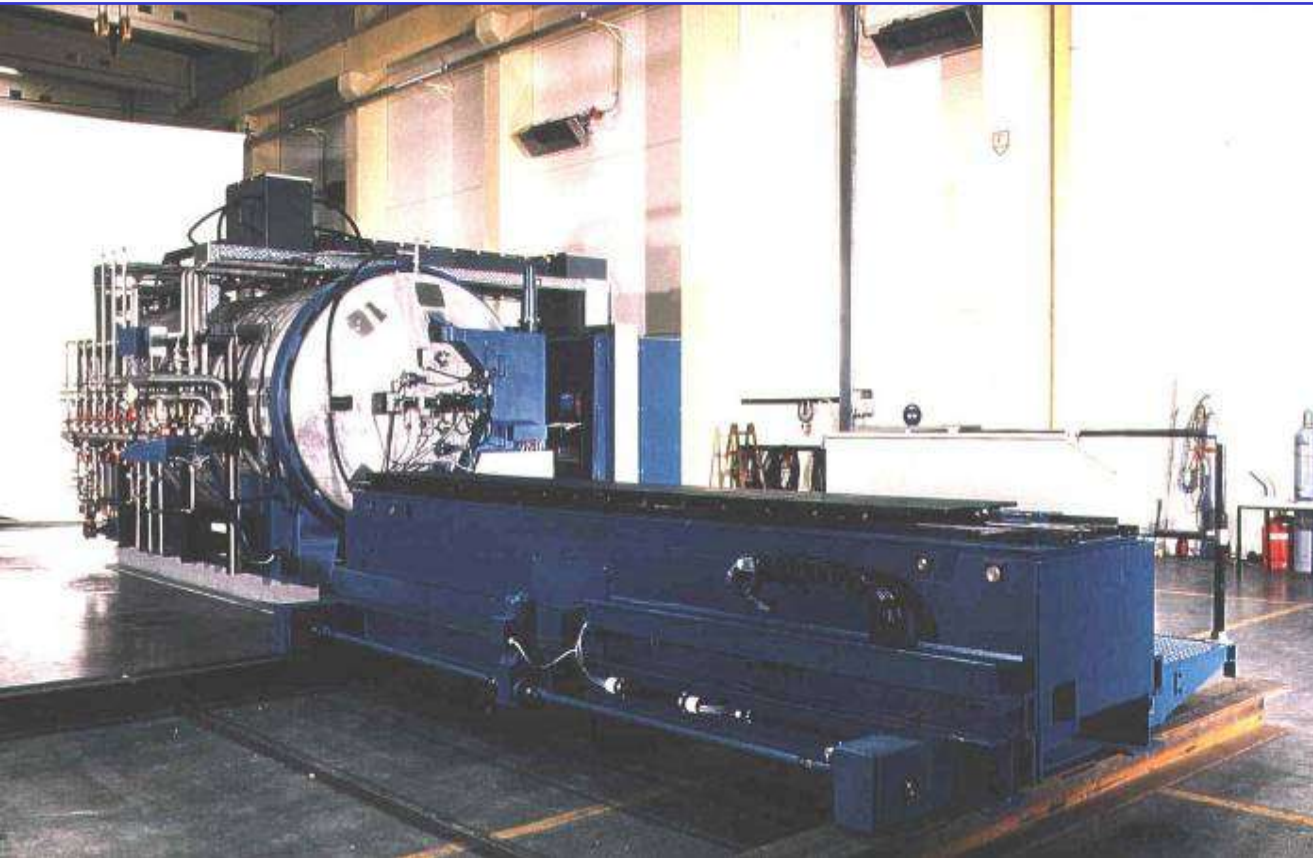

- useful volume  
1000 x 800 x 2500 mm
- rated temperature 2500°C
- controlled atmosphere  
Ar, N<sub>2</sub>, He  
up to 5 x 10<sup>-2</sup> mbar
- Loading device
- RSiC
- SSiC
- heat treatment



## Advanced sintering furnace (FH I)



- useful volume  
1450 x 1000 x 4000 mm
- rated temperature 2500°C
- controlled atmosphere  
Ar, N<sub>2</sub>, He  
up to 5 x 10<sup>-2</sup> mbar
- Loading device
  
- RSiC
- SSiC
- heat treatment

## Twin siliconizing furnaces for production line (FH W)



- useful furnace space  
800 x 800 x 600 mm
- rated temperature 2200°C
- controlled atmosphere  
Ar, N<sub>2</sub>, He,  
up to 5 x10<sup>-2</sup> mbar
- debinding – pyrolysis –  
siliconizing
- dewaxing
- sintering
- MIM, PIM

## Versatile lab hot press for R&D (HP W)



- 250 kN
- 2500 °C
- Ar / N<sub>2</sub>
- 10<sup>-2</sup> mbar

## Standard production hot press (HP W)



- 4000 kN
- 2200 °C
- Ar / N<sub>2</sub>
- 10<sup>-2</sup> mbar
- fast cooling
- loading device
- 7h – 2000°C cycle time
  
- sputter targets
- cutting tools

## FCT: Know how on mould design to succeed in hot pressing

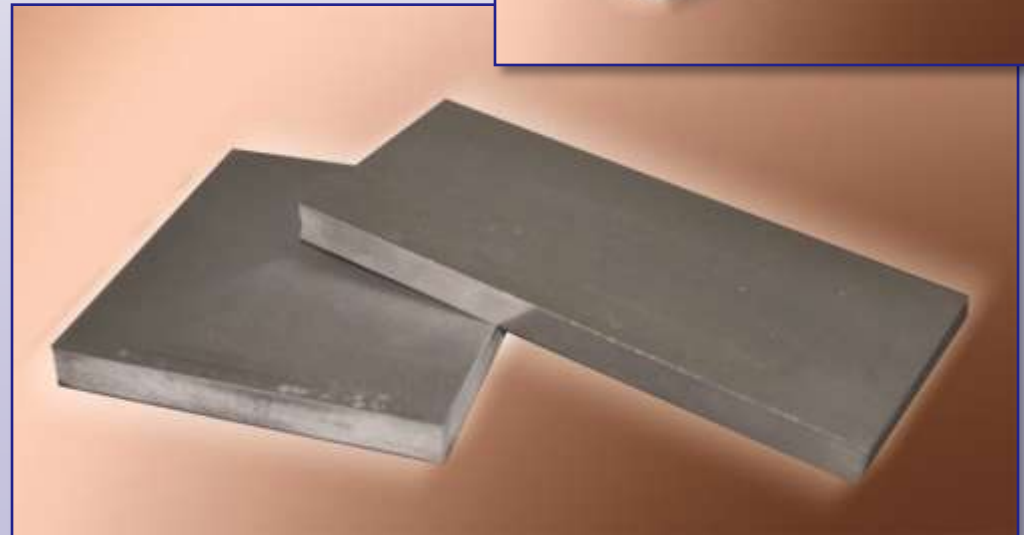
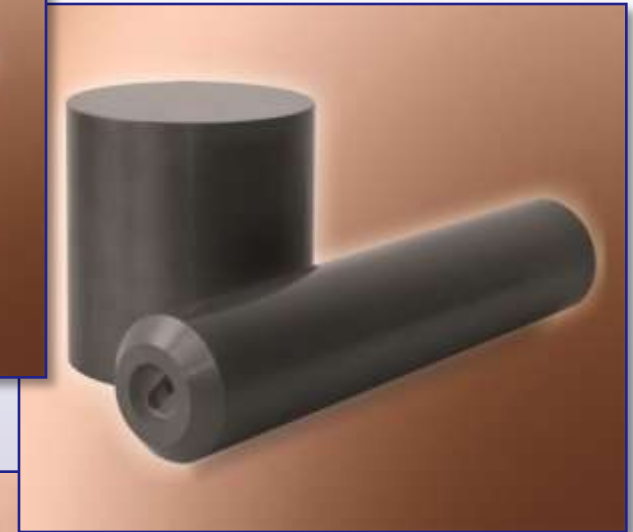
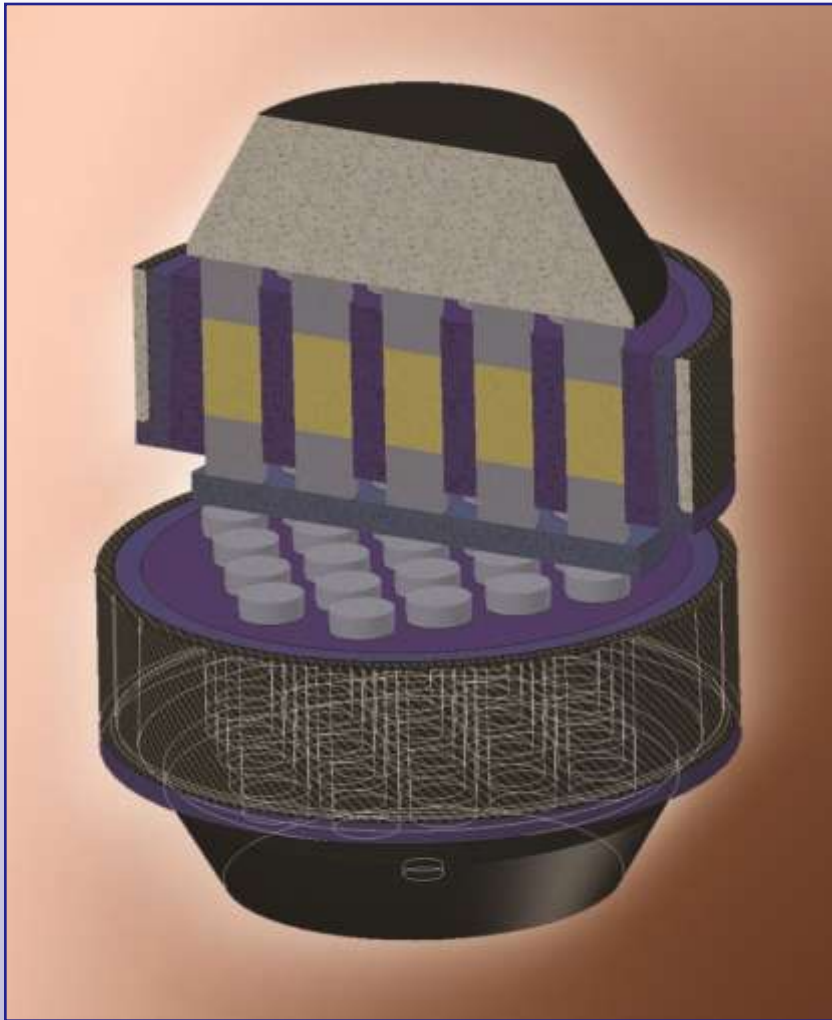

## **FAST/SPS furnace types ranging from 1.25 to 400 tons of pressing force (HP D)**



## SPS cycle of binderless WC using the HP D 250

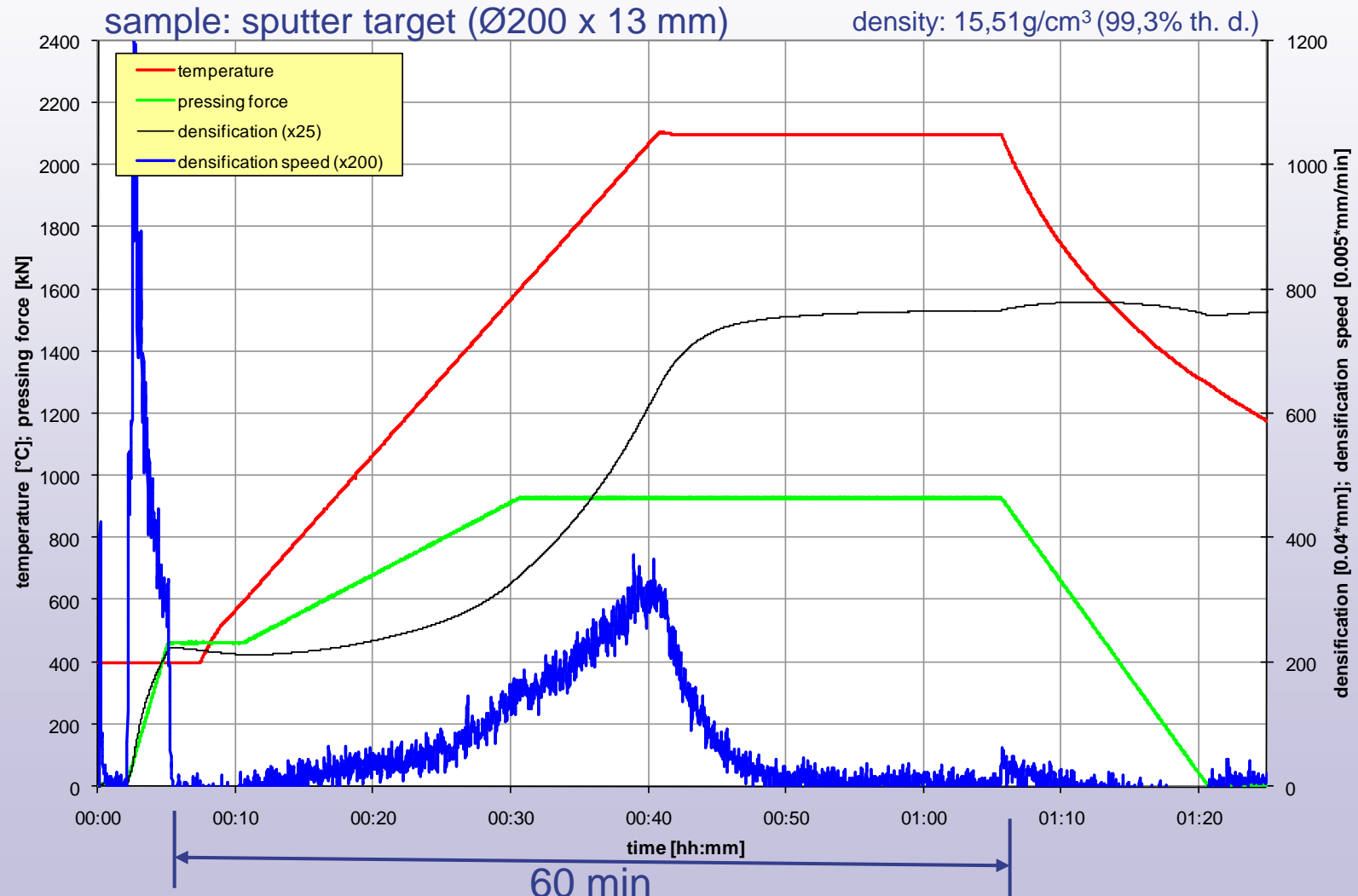

## 6-fold SPS-mold Ø63x34 Cr-cathodes

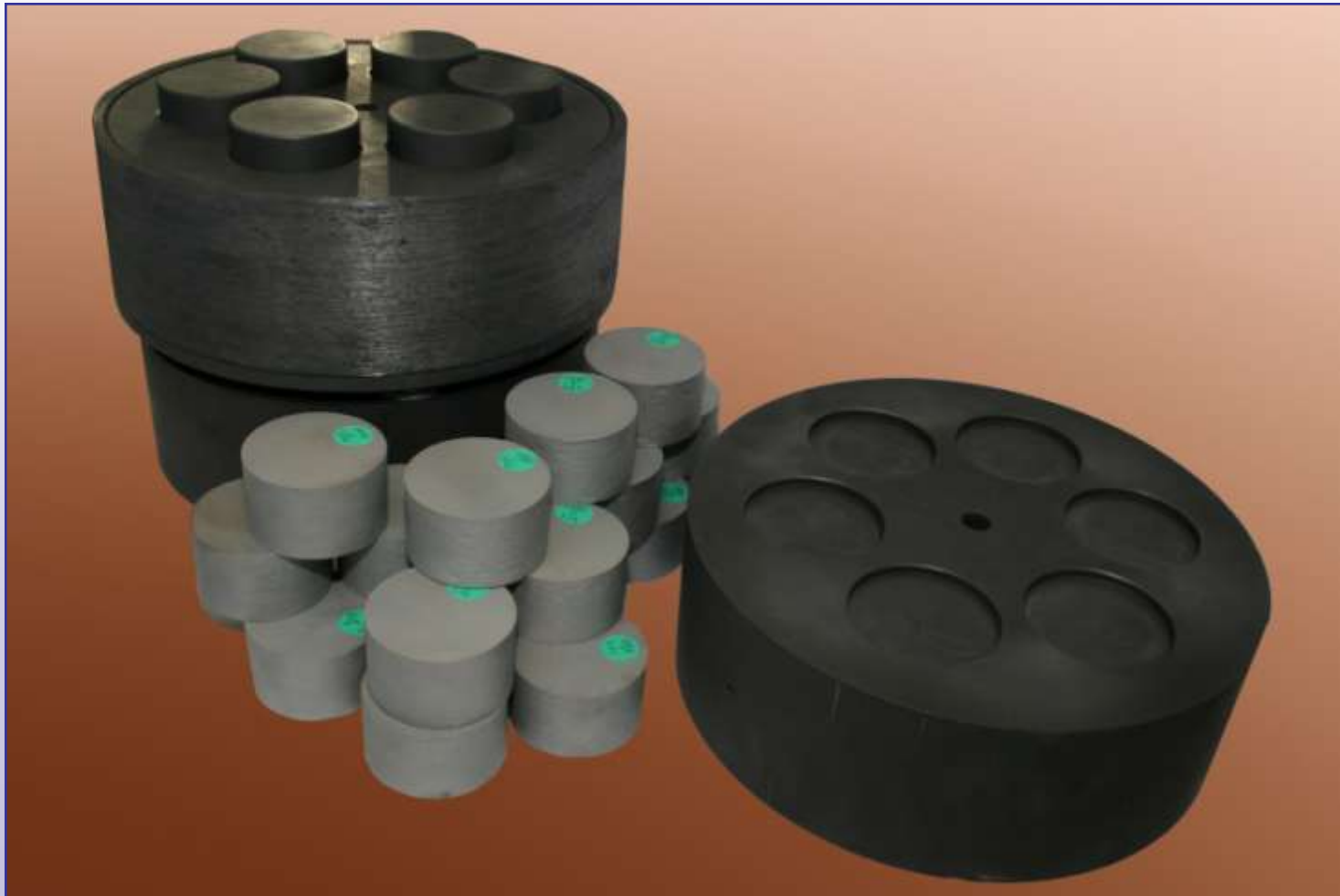



## Semi-continuous FAST-system (HP D/C)



Industrial Applications already in operation:

- ☺ Tungsten Carbide 175x150 :  $t_{\text{eff}} = 35 \text{ min}$
- ☺ Noble Metal D200 :  $t_{\text{eff}} = 20 \text{ min}$
- ☺ Chromium D60:  $t_{\text{eff}} = 10 \text{ min}$
- ☺ Ti / Al D100:  $t_{\text{eff}} = 4 \text{ min}$

360 kW - 2.500 kN

## FAST/Hybrid system (H-HP D 400)

- HHP D 400 hybrid heated FAST/SPS furnace
- Pressing force: 4000 kN
- Heating power FAST: 400 kW
- Heating power induction: 400 kW
- Max. part Ø: 450 mm



## Furnace PLC - Controller System

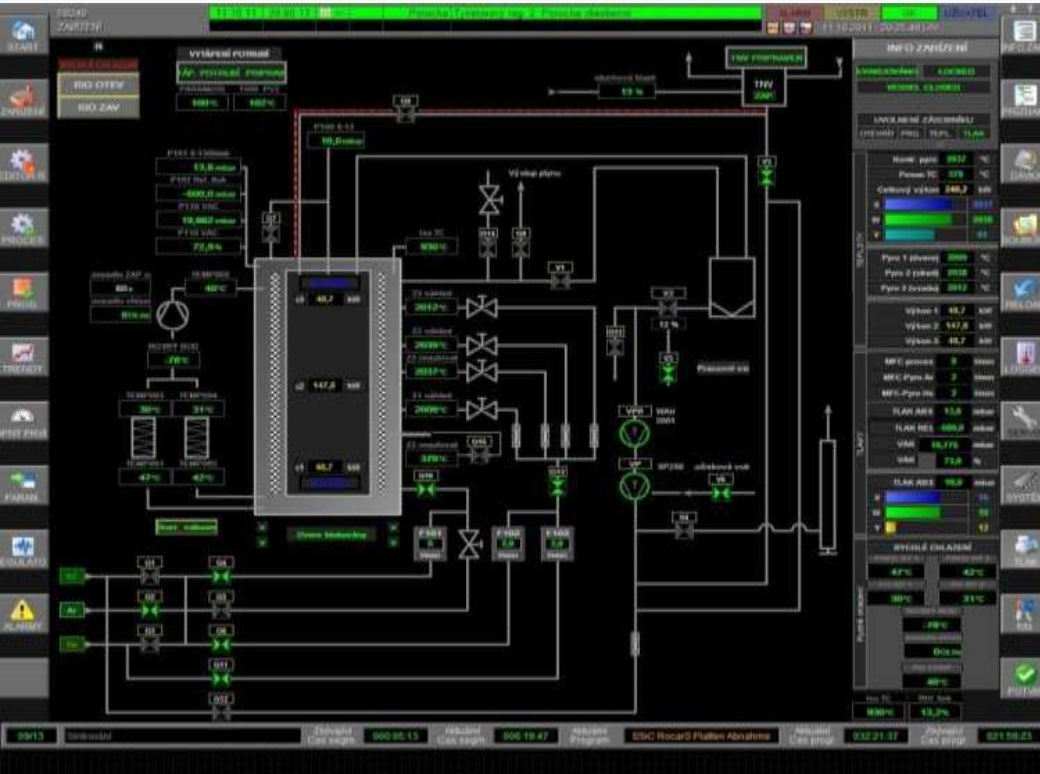

- **SIEMENS S7 + WINCC**
- process visualisation
- touchscreen monitor
- well-arranged display of all parameters relevant to the process
- trend display (history and actual time)
- data logging for every process
- recipe-management-system
- alarm display + history
- USB for control

## Commissioning and Training Support offered by FCT Systeme



- We offer the following support to our customers:
- complete set up and operation at FCT
- FAT together with the customer + first training in operation
- approval of all technical parameters
- set up at customer's site (SAT)
- complete commissioning and further training in operation and maintenance
- after-sales service

# Thank You For Your Attention

**Merci De Votre Attention**

**Gracias por su Atención**

**Grazie per la vostra attenzione**

**Obrigado para sua atenção**

**Σας ευχαριστώ για την προσοχή σας**

**Danke für Ihre Aufmerksamkeit**

**Dank u voor uw aandacht**

**TEŞEKKÜR**

**谢谢您的注意**

**清聴ありがとうございました**

**Благодарю для вашего внимания**

**너의 주의를 위해 너를 감사하십시요**

**Tack för Uppmärksamheten**

**Takk for Oppmerksomheten**